



ElectroSport
3803 Oceanic Dr. #201
Oceanside CA 92056
PH: 760-842-8300
FX: 760-842-8306
www.electrosport.com

ESC3700 Ignition Coil Fitting Instructions

APPLICATIONS

Kawasaki KX500 1989-ON (pulser coil ESP310 is also available)

Read these instructions completely

Step 1

Take the ignition cover off. **Are The Replacement Parts Similar?** Compare the replacement part to the original. The replacement part should match, including the mounting hole locations. If not: Double check the application listing with your bike.

Step 2

Take note of the wire colors of the original stator wires and disconnect them from the wiring loom.

Step 3

Remove the flywheel using a proper puller tool.

Step 4

Remove the baseplate with the original stator.

Step 5

Remove the screws that secure the ignition coil and take the coil off

Step 6

Cut the original BLACK/WHITE wire close to the original coil.

Connections

The original BLACK/WHITE wire connects to the ESC3700 WHITE wire. The other side of the ESC3700 is grounded with a tag under the left hand mounting screw. The original BLACK/YELLOW wire is grounded to the baseplate. The original WHITE/RED wire is connected to the pulser coil (ESP031)

Step 7

Connect the BLACK/WHITE wire from the original coil up to the WHITE wire of the new ESC3700 coil. Make sure you have a good connection here. Preferably crimp the connection using a high quality crimp. Otherwise use solder, but be aware that solder doesn't work very well on older wire. Use heat shrinking sleeve to insulate the connection.

Step 8

Mount the coil onto the baseplate. The ground tag of the coil needs to be at the top. Fit the screws using locking compound on the threads and **TIGHTEN THE SCREWS SECURELY!**

Step 9

Refit the stator baseplate. Ensure the wires **CANNOT TOUCH THE FLYWHEEL!** (especially on the inside of the flywheel)

Step 10

Refit the flywheel. Tighten the bolt to specified torque.

Step 11

Fit the ignition cover.

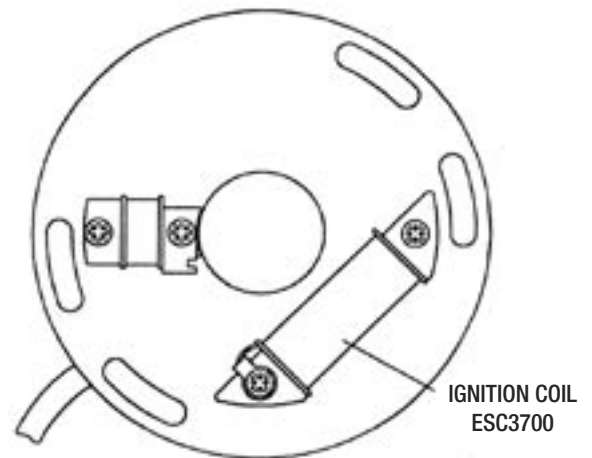
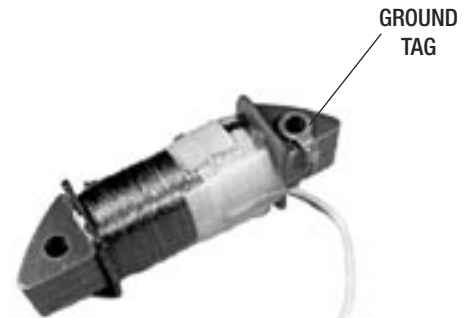

Troubleshooting

Engine will not start: Sometimes the source coil wires are reversed. Swap the connections, resolder the wires and the engine should start. If the engine still does not start, and **before calling technical support at ElectroSport**, perform a few basic tests: 1) Re-check the connections. Make sure you carefully solder the connections. Twisting wires together or taping wires will cause engine inoperability. 2) Check the engine for spark and 3) Is fresh fuel in the gas tank? If you still cannot get the engine to start, have all your testing information ready for a technician prior to calling.