

## ESC1656 IGNITION COIL SET - Fitting

### APPLCIATION: YAMAHA YZ250 (1988-1989)

**Step 1** Take the ignition cover off. Are The Replacement Parts Similar? Compare the replacement part to the original. The replacement part can look different because of the winding technology used, but the mounting hole locations should match. Be sure to note the location of the OEM part on the baseplate and which wires are connecting to it.

**Step 2** Take note of the wire colors of the original coil wires and disconnect them from the wiring loom.

**Step 3** Remove the flywheel using a proper puller tool. Remove the baseplate with the original coil. Remove the screws that secure the coil and take the coil off.

**Step 4** Cut the original RED wire close to the original coil. Take a good look at how the wires are connected to the coil. (at which side of the original coils and where each wire color goes)

**CONNECTIONS** LARGE coil connects to the BROWN wire, the other side is grounded through a ground tag under the mounting screw. SMALL coil connects to the WHITE/RED wire, and the other side is either grounded or connected over to the LARGE coil with a BROWN jumper wire. (You will have to see what the original setup is, because Yamaha uses different systems)

**Step 5** Connect the old wires up to the new coils. Put the wires in exactly the same place as on the original. Make sure you have good connections here. Use a soldering iron and resin core solder (the type used in electrical applications).

**Step 6** Mount the coils onto the baseplate, fit the screws using locking compound on the threads and TIGHTEN THE SCREWS SECURELY! Refit the stator baseplate. Ensure the wires CANNOT TOUCH THE FLYWHEEL! (especially on the inside of the flywheel) Refit the flywheel. Tighten the bolt to specified torque. Connect the wires to the wiring loom on the bike. Refit the ignition cover.

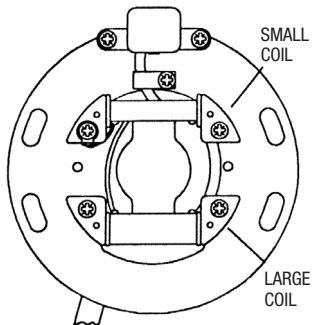

**Troubleshooting:** Engine will not start: Sometimes the source coil wires are reversed on the smaller coil. You can test this by swapping out the connections. For OHMS testing, measure from the ground tag and solder tag. The OMS reading in the factory service manual will most likely be different than what is listed for the replacement part. This is due to the high performance winding technology. If you have further technical questions, please refer to your service manual.

**OHMS LARGE COIL: 320  $\Omega$   $\pm$  10%**

**OHMS SMALL COIL: 50  $\Omega$   $\pm$  10%**